

STANDARD SOFT BLANK JAW

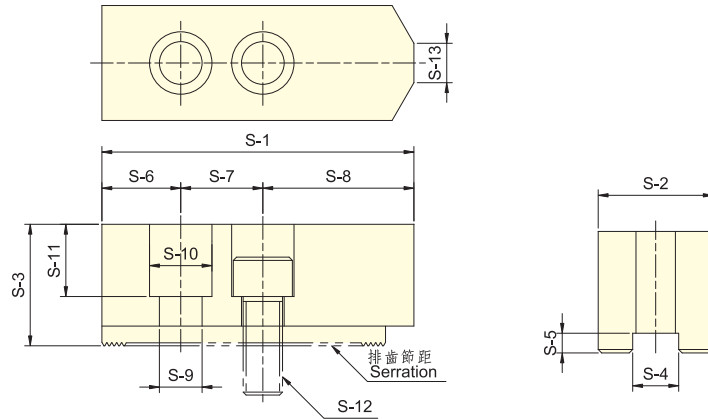
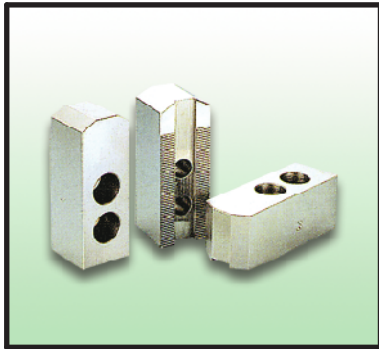

保留規格修改的權利
Subject to technical changes.

尺寸 Dim 型式 Model	S-1	S-2	S-3	S-4	S-5	S-6	S-7	S-8	S-9	S-10	S-11	S-12	S-13	排齒節距 Serration Pitch	適用夾頭 Matching Chuck	三爪重量(kg) 3 Jaw Weight (kg)	
SJ04	52	23	23	10	5	10	14	28	9	14	13	M8	3	1.5x60°	3H-04,3P-04	0.5	
SJ05	62	25	30					38			18		3.5		3H-05, 3L-05 3P-05, 3M-05	0.8	
SJ06	73	31	36	12		15	20	38	11	17	24	M10	14		3H-06, 3L-06 3P-06, 3M-06	1.5	
SJ08	95	35	37	14		24	25	46	13	19	22	M12	16		3H-08, 3L-08 3P-08, 3M-08	2.4	
SJ10	110	40	42	16		30	50	60	18	26	27		18		3H-10, 3L-10 3P-10, 3M-10	3.7	
SJ12H	130	50	50	21		40	30	60	16	23	33	M16	23		3.0x60°	3H-12, 3L-12, 3V-12 3P-12, 3M-12	6.3
SJ12P				18	3P-12											6.5	
SJ15H	165	62	62	22	8	37	43	85	21	32	38	M20	-		3H-15, 3H-18, 3L-15 3P-15, 3P-18, 3V-15, 3V-18	12.5	
SJ15P				25.5											3H-21, 3H-24, 3P-21 3P-24, 3V-21, 3V-24	15.8	
SJ21	180	65	70	25	9	40	60	80			45						